



Air Conditioning & Heating



DUALSAVER
TWO-STAGE HEATING PERFORMANCE

PRODUCT SPECIFICATIONS

GMH8/GDH8

80% AFUE

MULTI-POSITION,
TWO-STAGE (CONVERTIBLE),
MULTI-SPEED GAS FURNACES

HEATING INPUT:
45,000-140,000 BTU/H



The Goodman® GMH8/GDH8 80% AFUE Two-Stage (Convertible), Multi-Speed Multi-Position Gas Furnaces feature a patented aluminized-steel tubular heat exchanger and durable Silicon Nitride Hot Surface Ignition system. This furnace is run-tested for heating or combination heating/cooling applications. With a heavy-gauge, reinforced, insulated steel cabinet and durable baked enamel finish, this unit can be installed in a variety of locations.

Standard Features

- Patented TuffTube™ dual-diameter tubular heat exchanger with lifetime limited warranty plus 10-year limited furnace replacement warranty
- Two-stage gas valve with revolutionary new convertible technology that allows installer to activate two-stage operation with the flip of a dipswitch
- Silicon Nitride igniter with patented adaptive learning control for maximum igniter life
- Furnace control board with self-diagnostics, color-coded low-voltage terminals and provisions for electronic air cleaner and 24 volt humidifiers
- Control board stores the last five diagnostic codes in memory; simple push-button activation outputs the fault history to a flashing red LED
- Low constant fan allows homeowner to activate the low heat speed to efficiently circulate air throughout the home.
- Self-adjusting feature automatically adjusts furnace to high or low stage based on outside temperature without an outdoor temperature sensor

Cabinet Features

- Fully insulated, heavy-gauge steel cabinet with durable baked-enamel finish
- Foil-faced insulation lines the heat exchanger
- Designed for multi-position installation: upflow, horizontal left or right
- Removable bottom for side or bottom return applications
- Convenient left or right connection for gas and electric service
- Coil and furnace fit flush for most installations

* For full warranty details, visit www.goodmanmfg.com.



PRODUCT SPECIFICATIONS

NOMENCLATURE

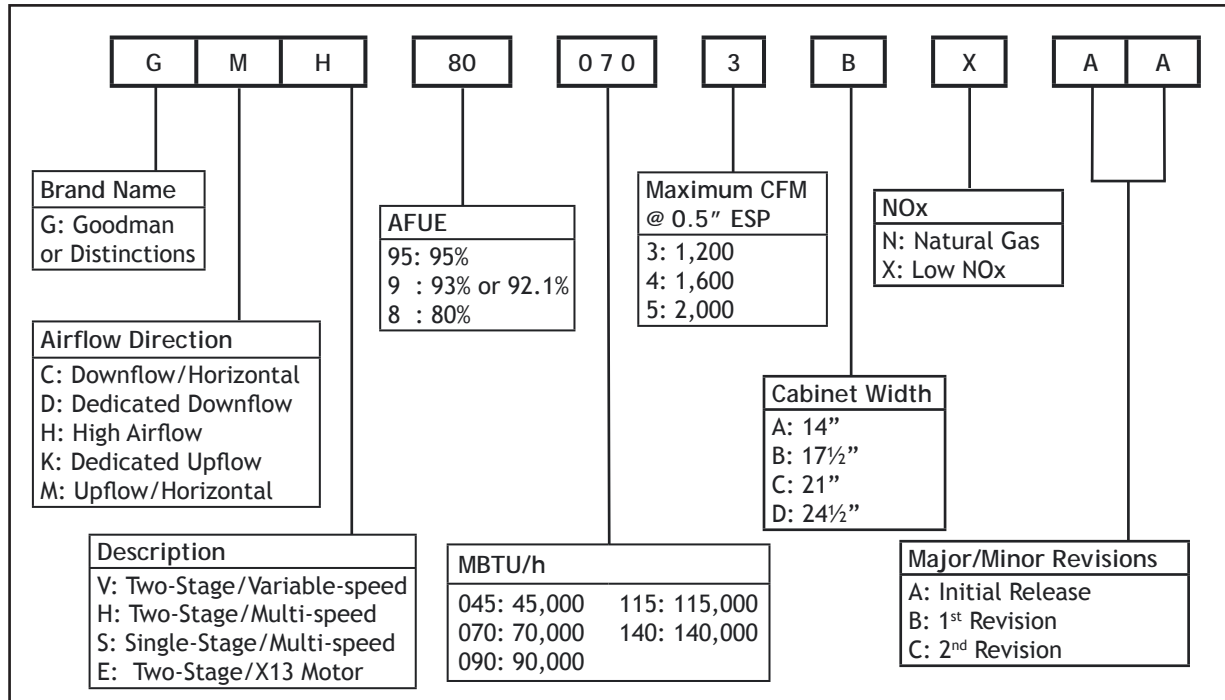

ACCESSORIES

Model	Description	GMH8 All Models	GDH8 All Models
LPM-05	LP Conversion Kit (Springs & Orifice)	✓	✓
HA02	High-Altitude Natural Gas Kit	✓	✓
AFE18-60A	Fossil Fuel Kit	✓	✓
SBT 14/17/21*	Downflow Sub-base		✓

* Supplied by McDaniel Metals

THERMOSTATS

Model	Description
CHT18-60	Cooling/Heating, Mechanical
CH70TG	Cooling/Heating, Digital, Non-programmable
CHSATG	Cooling/Heating, Mechanical
H20TWR	Heating Only, Mechanical

SPECIFICATIONS

	GMH8 0453AN*	GMH8 0703AN*	GMH8 0704BN*	GMH8 0903BN	GMH8 0904BN*	GMH8 0905CN*	GMH8 1155CN*	GMH8 1405DN*	GDH8 0453AX	GDH8 0703AX	GDH8 0904BX	GDH8 1155CX
Heating Capacity												
Input ¹	45,000	70,000	70,000	90,000	90,000	90,000	115,000	140,000	45,000	70,000	90,000	115,000
Natural Gas Output ¹	36,000	56,000	56,000	72,000	72,000	72,000	92,000	112,000	36,000	56,000	72,000	92,000
LP Gas Output ¹	32,000	48,000	48,000	64,000	64,000	64,000	80,000	96,000	32,000	48,000	64,000	80,000
AFUE ²	80	80	80	80	80	80	80	80	80	80	80	80
Available AC @ 0.5" ESP	3	3	4	3	4	5	5	5	25 - 55	25 - 55	30 - 60	40 - 70
Temperature Rise Range (°F)	25 - 55		20 - 50	30 - 60	35 - 65			40 - 70	3	3	4	5
Circulator Blower												
Size (D x W)	10"x 6"		10"x 8"			10"x 10"			10"x 6"	10"x 6"	10"x 8"	10"x10"
Horsepower @ 1750 RPM	1/3		1/2	1/3	1/2			3/4	1/3	1/3	1/2	1/2
Speed	4	4	4	4	4	4	4	4	4	4	4	4
Vent Diameter ³	4"	4"	4"	4"	4"	4"	4"	4"	4"	4"	4"	4"
No. of Burners	2	3	3	4	4	4	5	6	2	3	4	5
Filter Size (in²)												
Permanent ⁴	290		385	290	385	480			290	290	385	480
Disposable	580		770	580	770	960			580	580	770	960
Electrical Data												
Min. Circuit Ampacity ⁵	8.1		12.5	8.1	12.5			14.7	8.5	8.5	12.9	12.9
Max. Overcurrent Protection ⁶	15 amps											
Ship Weight (lbs)	120	130	143	153		163			120	130	153	175

* Low NOx model available

1- Natural Gas BTU/h; for altitudes above 2,000', reduce input rating 4% for each 1,000' above sea level.

Low-fire rate is 75% of high-fire rate

2- DOE AFUE based upon Isolated Combustion System (ICS)

3- Vent diameter may vary depending upon vent length. Refer to the latest editions of the National Fuel Gas Code

NFPA 54/ANSI Z223.1 (in the USA) and the Canada National Standard of Canada, CAN/CSA B149.1 and CAN/CSA B142.2 (in Canada).

4- Permanent air filter size is based on 600 FPM velocity. Check with filter manufacturer for specific details.

5- Minimum Circuit Ampacity = (1.25 x Circulator Blower Amps) + ID Blower amps. Wire size should be determined in accordance with National Electrical Codes. Extensive wire runs will require larger wire sizes.

6- Refers to maximum recommended fuse or circuit breaker size. May use fuses or HACR-type circuit breakers of the same size as noted.

Notes:

- All furnaces are manufactured for use on 115 VAC, 60 Hz, single-phase electrical supply.
- Gas Service Connection 1/2" FPT
- Important: Size fuses and wires properly and make electrical connections in accordance with the National Electrical Code and/or all existing local codes.

PRODUCT SPECIFICATIONS

GMH8 DIMENSIONS

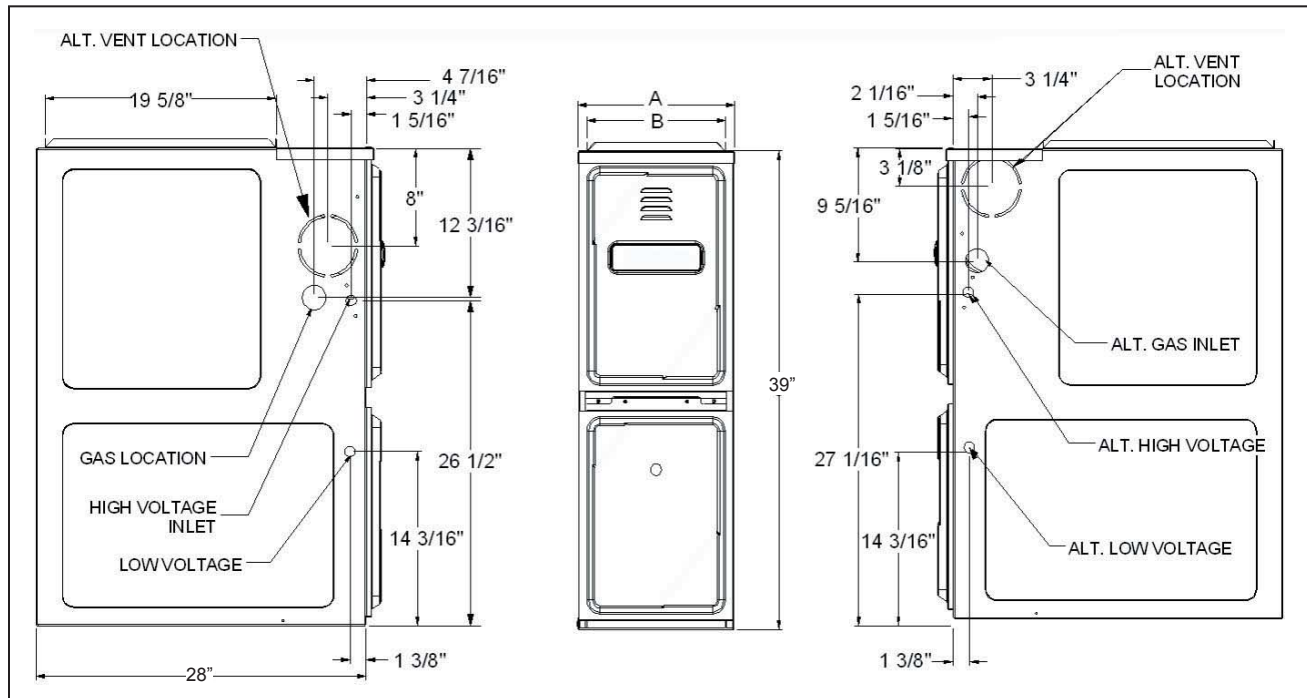

Model	A	B
GMH80453AN*	14"	12½"
GMH80703AN*	14"	12½"
GMH80704BN*	17½"	16"
GMH80903BN	17½"	16"

Model	A	B
GMH80904BN*	17½"	16"
GMH80905CN*	21"	19½"
GMH81155CN*	21"	19½"
GMH81405DN*	24½"	23"

* Low NOx model available.

MINIMUM CLEARANCES TO COMBUSTIBLE MATERIALS

Sides	Rear	Front ¹	Vent ²		Top
			SW	B	
1"	0"	3"	6"	1"	1"

¹ 24" clearance for serviceability recommended.

² Single Wall Vent (SW) to be used only as a connector. Refer to the latest editions of the National Fuel Gas Code NFPA 54/ANSI Z223.1 (in the USA) and the Canada National Standard of Canada, CAN/CSA B149.1 and CAN/CSA B142.2 (in Canada).

Note: GMH8 approved for line contact in the horizontal position.

GDH8 DIMENSIONS

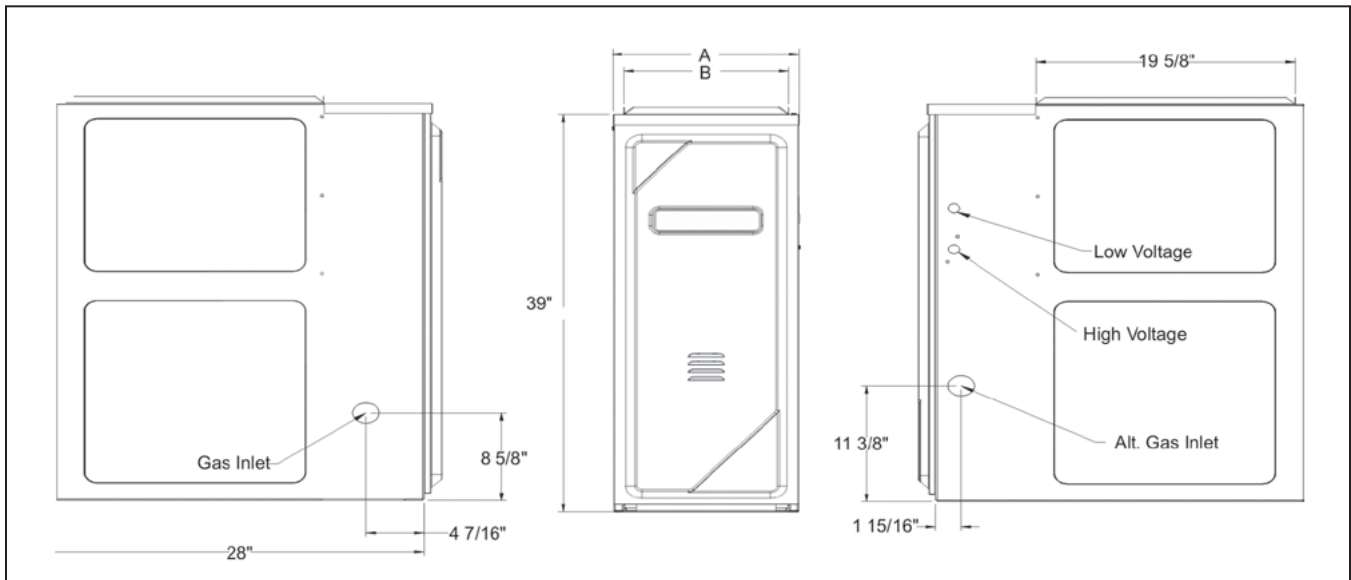

Model	A	B	Non-Combustible Floor Base
GDH80453AXAA	14"	12½"	SBT14
GDH80703AXAA	14"	12½"	SBT14
GDH80904BXAA	17½"	16"	SBT17
GDH81155CXAA	21"	19½"	SBT21

Notes:

- Line voltage wiring can enter through the right or left side of furnace. Low-voltage wiring can enter through the right or left side of furnace.
- Conversion kits for high-altitude natural gas operation are available. Contact your Goodman distributor or dealer for details.
- Installer must supply the following gas line fittings, according to which entrance is used:
 - ◊ Left: One 90° street elbow; one 2½" pipe nipple; one 90° elbow; straight pipe; one ground joint union
 - ◊ Right: Straight pipe to reach gas valve

MINIMUM CLEARANCES TO COMBUSTIBLE MATERIALS

Sides	Rear	Front ¹	Vent ²		Top
			SW	B	
1"	0"	3"	6"	1"	1"

¹ 24" clearance for serviceability recommended.

² Single Wall Vent (SW) to be used only as a connector. Refer to the latest editions of the National Fuel Gas Code NFPA 54/ ANSI Z223.1 (in the USA) and the Canada National Standard of Canada, CAN/CSA B149.1 and CAN/CSA B142.2 (in Canada).

PRODUCT SPECIFICATIONS

GMH8 BLOWER PERFORMANCE SPECIFICATIONS

(CFM & Temperature Rise vs. External Static Pressure)

Model (Heating Speed as Shipped)	Motor Speed	Tons AC at 0.5" ESP	External Static Pressure, (Inches Water Column)												
			0.1		0.2		0.3		0.4		0.5		0.6	0.7	0.8
			CFM	Rise	CFM	Rise	CFM	Rise	CFM	Rise	CFM	Rise	CFM	CFM	CFM
GMH80453AN* (Medium)	High	3	1,555	---	1,511	---	1,459	---	1,392	---	1,344	25	1,279	1,201	1,120
	Med	2.5	1,165	28	1,123	30	1,100	30	1,090	30	1,048	32	1,017	970	903
	Med-Lo	2	927	36	907	37	889	37	863	38	853	39	822	800	746
	Low	1.5	699	47	694	48	668	50	645	51	636	52	592	566	524
GMH80703AN* (Medium)	High	3	1,437	36	1,310	39	1,295	40	1,310	39	1,273	41	1,202	1,129	1,039
	Med	2.5	1,127	46	1,100	47	1,095	47	1,075	48	1,050	49	1,018	967	904
	Med-Lo	2	895	---	917	---	878	---	867	---	853	---	830	786	743
	Low	1.5	694	---	681	---	663	---	640	---	625	---	591	562	522
GMH80704BN* (Medium)	High	4	2,234	23	2,151	24	2,076	25	1,990	26	1,897	27	1,803	1,710	1,569
	Med	3.5	1,676	31	1,653	31	1,648	31	1,581	33	1,555	33	1,492	1,414	1,352
	Med-Lo	3	1,342	38	1,335	39	1,321	39	1,313	39	1,291	40	1,261	1,215	1,149
	Low	2.5	1,089	47	1,085	48	1,078	48	1,071	48	1,057	49	1,040	986	932
GMH80903BN (Medium)	High	3	1,593	42	1,561	43	1,567	42	1,543	43	1,493	44	1,420	1,343	1,230
	Med	2.5	1,186	56	1,160	57	1,160	57	1,135	58	1,118	59	1,089	1,045	983
	Med-Lo	2	957	---	940	---	937	---	921	---	895	---	861	826	778
	Low	1.5	742	---	710	---	685	---	663	---	635	---	611	578	476
GMH80904BN* (Medium)	High	4	2,182	---	2,127	31	2,056	32	1,974	33	1,895	35	1,809	1,715	1,588
	Med	3.5	1,645	40	1,628	40	1,615	40	1,597	41	1,541	43	1,491	1,440	1,350
	Med-Lo	3	1,320	49	1,305	49	1,310	49	1,310	50	1,295	51	1,267	1,217	1,139
	Low	2.5	1,063	60	1,061	60	1,057	61	1,056	61	1,039	61	1,025	1,005	948
GMH80905CN* (Medium)	High	5	2,334	---	2,334	---	2,284	---	2,135	---	2,051	35	1,910	1,748	1,605
	Med	4	1,754	39	1,735	39	1,728	40	1,685	40	1,628	42	1,551	1,469	1,346
	Med-Lo	3.5	1,367	47	1,380	47	1,371	47	1,374	48	1,335	50	1,293	1,246	1,165
	Low	3	1,098	58	1,109	59	1,109	59	1,088	60	1,066	62	1,050	998	916
GMH81155CN* (Medium)	High	5	2,481	---	2,395	35	2,288	37	2,217	38	2,076	41	1,999	1,858	1,732
	Med	4	1,738	49	1,732	49	1,709	50	1,686	50	1,639	52	1,585	1,492	1,385
	Med-Lo	3.5	1,364	62	1,378	62	1,372	62	1,372	62	1,350	63	1,313	1,261	1,125
	Low	3	1,137	---	1,142	---	1,140	---	1,114	---	1,090	---	1,056	954	860
GMH81405DN* (Medium)	High	5	2,554	41	2,435	43	2,375	44	2,240	47	2,152	49	2,002	1,883	1,744
	Med	4	1,846	57	1,773	59	1,762	60	1,712	61	1,672	63	1,583	1,526	1,442
	Med-Lo	3.5	1,520	69	1,500	70	1,483	---	1,470	---	1,435	---	1,373	1,308	1,245
	Low	3	1,301	---	1,274	---	1,260	---	1,231	---	1,207	---	1,177	1,093	931

* Low NOx model available.

Notes:

- CFM in chart is without filter(s). Filters do not ship with this furnace, but must be provided by the installer.
- All furnaces ship as high-speed cooling and medium-speed heating. Installer must adjust blower cooling and heating speed as needed.
- For most applications, about 400 CFM per ton when cooling is desirable.
- INSTALLATION IS TO BE ADJUSTED TO OBTAIN TEMPERATURE RISE WITHIN THE RANGE SPECIFIED ON THE RATING PLATE.
- The chart is for information only. For satisfactory operation, external static pressure must not exceed value shown on the rating plate. The shaded area indicates ranges in excess of maximum static pressure allowed when heating.
- The dashed (---) areas indicate a temperature rise not recommended for this model.
- The above chart is for furnaces installed at 0-2000 feet. At higher altitudes, a properly de-rated unit will have approximately the same temperature rise at a particular CFM, while ESP at the CFM will be lower.

GDH8 BLOWER PERFORMANCE SPECIFICATIONS

(CFM & Temperature Rise vs. External Static Pressure)

Model (Heating Speed as Shipped)	Motor Speed	Tons AC at 0.5” ESP	External Static Pressure, (Inches Water Column)												
			0.1		0.2		0.3		0.4		0.5		0.6	0.7	0.8
			CFM	Rise	CFM	Rise	CFM	Rise	CFM	Rise	CFM	Rise	CFM	CFM	CFM
GDH8 0453AX (Med)	High	3.0	1,435	---	1,421	---	1,380	---	1,322	25	1,262	26	1,200	1,144	1,064
	Med	2.5	1,140	29	1,114	30	1,084	31	1,063	31	1,039	32	1,002	943	897
	Med-Lo	2.0	899	37	889	37	875	38	871	38	857	39	821	780	745
	Low	1.5	691	48	674	49	665	50	651	51	637	52	618	562	525
GDH8 0703AX (Med)	High	3.0	1,406	37	1,393	37	1,379	37	1,307	39	1,262	41	1,208	1,145	1,070
	Med	2.5	1,153	45	1,101	47	1,077	48	1,039	50	1,028	50	987	947	885
	Med-Lo	2.0	890	---	896	---	873	---	862	---	834	---	798	771	727
	Low	1.5	690	---	682	---	664	---	631	---	616	---	583	549	509
GDH8 0904BX (Med)	High	4.0	2,007	---	1,993	---	1,975	---	1,940	---	1,844	36	1,770	1,668	1,559
	Med	3.5	1,612	41	1,606	41	1,570	42	1,533	43	1,501	44	1,448	1,373	1,301
	Med-Lo	3.0	1,325	50	1,299	51	1,280	52	1,244	53	1,222	54	1,186	1,140	1,079
	Low	2.5	1,043	---	1,040	---	1,032	---	1,002	---	981	---	955	915	869
GDH8 1155CX (Med)	High	5.0	2,381	---	2,312	---	2,312	---	2,219	---	2,134	40	2,024	1,930	1,839
	Med	4.0	1,801	47	1,667	51	1,667	51	1,638	52	1,613	53	1,513	1,441	1,369
	Med-Lo	3.5	969	---	1,062	---	1,140	---	1,223	69	1,269	67	1,292	1,322	1,358
	Low	3.0	1,100	---	1,094	---	1,060	---	1,031	---	1,001	---	953	937	874

Notes:

- CFM in chart is without filter(s). Filters do not ship with this furnace, but must be provided by the installer. If the furnace requires two return filters, this chart assumes both filters are installed.
- All furnaces ship as high-speed cooling and medium-speed heating. Installer must adjust blower cooling and heating speed as needed.
- For most jobs, about 400 CFM per ton when cooling is desirable.
- INSTALLATION IS TO BE ADJUSTED TO OBTAIN TEMPERATURE RISE WITHIN THE RANGE SPECIFIED ON THE RATING PLATE.
- This chart is for information only. For satisfactory operation, external static pressure must not exceed value shown on the rating plate. The shaded area indicates ranges in excess of maximum static pressure allowed when heating.
- The dashed (----) areas indicate a temperature rise not recommended for this model.
- The above chart is for U.S. furnaces installed at 0-2000 feet. At higher altitudes, a properly derated unit will have approximately the same temperature rise at a particular CFM, while ESP at the CFM will be lower.

PRODUCT SPECIFICATIONS

DUAL\$AVER CONFIGURATION & OPERATION

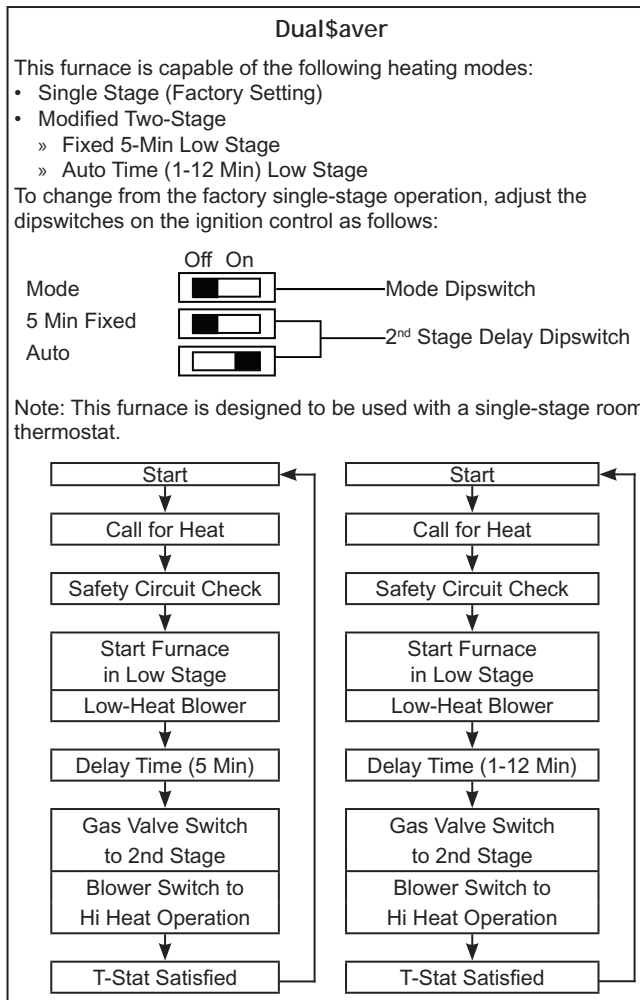

Goodman Manufacturing Company, L.P., reserves the right to discontinue, or change at any time, specifications or designs without notice or without incurring obligations.

*Copyright © 2006 • Goodman Manufacturing Company, L.P. • Houston, Texas
Goodman® brand products are proudly made in the USA.
Printed in the USA.*