



Air Conditioning & Heating

# ASPF

## MULTI-POSITION AIR HANDLER WITH ENERGY-SAVING MOTOR

### 1½ TO 5 TONS

#### Standard Features

- Suitable for use with refrigerants R-410A and R-22
- All-aluminum evaporator coil
- Check flowrate expansion device for cooling and heat pump applications
- EEM multi-speed motor
- Enhances the performance of your Goodman® brand air conditioner or heat pump
- Multi-position — upflow, downflow or horizontal
- Built-in coil has horizontal, vertical, and downflow drain pans with secondary drain connections
- Complies with the Factory-Sealed Air Handling Credit as listed in the 2001 Florida Building Code, Chapter 13, Section 610.2.A.2.1
- AHRI Certified; ETL Listed

#### Cabinet Features

- Fully insulated, painted steel cabinet with attractive Architectural Gray finish
- Built-in filter rack for 1" filter (filter not included)
- Low-voltage cabinet connections
- Power supply on top
- Low-voltage entry on top or side
- Factory sealed to achieve 2% or less leakage rate at 1.0" water gauge external duct static pressure



\* Complete warranty details available from your local dealer or at [www.goodmanmfg.com](http://www.goodmanmfg.com). To receive the 10-Year Parts Limited Warranty, online registration must be completed within 60 days of installation. Online registration is not required in California or Québec.



NOMENCLATURE

	A	S	P	F	2405	1	6	AA
	1	2	3	4	5,6,7,8	9	10	11,12
<b>Brand</b>								
A Single-piece Air Handler								
<b>Unit Application</b>								
C Ceiling Mount PSC Motor								
D Downflow PSC Motor								
E Multi-Position Variable-Speed Motor								
R Multi-Position PSC Motor								
S Multi-Position EEM Motor								
W Wall Mount PSC Motor								
<b>Cabinet Finish</b>								
U Unpainted								
P Painted								
N Uncased								
<b>Expansion Device</b>								
F Flowrater								
T Expansion Valve								
	<b>Engineering *</b>							
	Major/ Minor Revisions							
	* Not used for inventory management							
	<b>Refrigerant Charge</b>							
	No Digit = R-22 only							
	6 = R-410A or R-22							
	<b>Electrical</b>							
	1 208/240 V, 1 Phase, 60 Hz							
	<b>Nominal Capacity Range @ 13 SEER</b>							
	<b>Multi-Position &amp; Downflow Applications</b>							
	1729 1½ to 2½ Tons (for Export Systems)							
	1830 1½-3½ Tons							
	3642 3-3½ Tons							
	<b>Ceiling Mount &amp; Wall Mount Applications</b>							
	(Nominal Cooling Capacity/ Electric Heat kW)							
	1805 1½ Tons Cooling/ 5 kW Electric Heat							
	2405 2 Tons Cooling/ 5 kW Electric Heat							
	3608 3 Tons Cooling/ 8 kW Electric Heat							



**SPECIFICATIONS**

	<b>ASPF 183016*</b>	<b>ASPF 303616*</b>	<b>ASPF 313716*</b>	<b>ASPF 426016*</b>
<b>NOMINAL RATINGS</b>				
Cooling (BTU/h)	18,000 - 30,000	30,000 - 36,000	30,000 - 36,000	42,000 - 60,000
CFM (High/ Low)	1,085 / 650	1,350 / 600	1,350 / 600	2,000 / 1,040
<b>BLOWER</b>				
Diameter	9½"	10⅝"	10⅝"	10 <sup>15</sup> / <sub>16</sub> "
Width	8"	10⅝"	10⅝"	10 <sup>11</sup> / <sub>16</sub> "
Coil Drain Connection FPT	¾"	¾"	¾"	¾"
<b>SERVICE VALVE</b>				
Liquid	⅜"	⅜"	⅜"	⅜"
Suction	¾"	⅞"	⅞"	⅞"
<b>ELECTRICAL DATA</b>				
Voltage	208 / 230	208 / 230	208 / 230	208 / 230
Electric Heat Capacity (kW)	5, 8, 10	3, 5, 6, 8, 10, 15, 20, 21	3, 5, 6, 8, 10, 15, 20, 21	10, 15, 20, 21
Min Circuit Ampacity	3.6 / 3.6	3.8 / 3.8	3.9 / 3.9	6.6 / 6.6
Max. Overcurrent Device	15 / 15 amps	15 / 15 amps	15 / 15 amps	15 / 15 amps
Min. / Max VAC	197 / 253	197 / 253	197 / 253	197 / 253
Blower Motor FLA/ HP	2.9 / ½	3.0 / ¼	3.1 / ¼	5.1 / ¼
<b>SHIP WEIGHT (LBS)</b>	125	176	176	195

**DIMENSIONS**

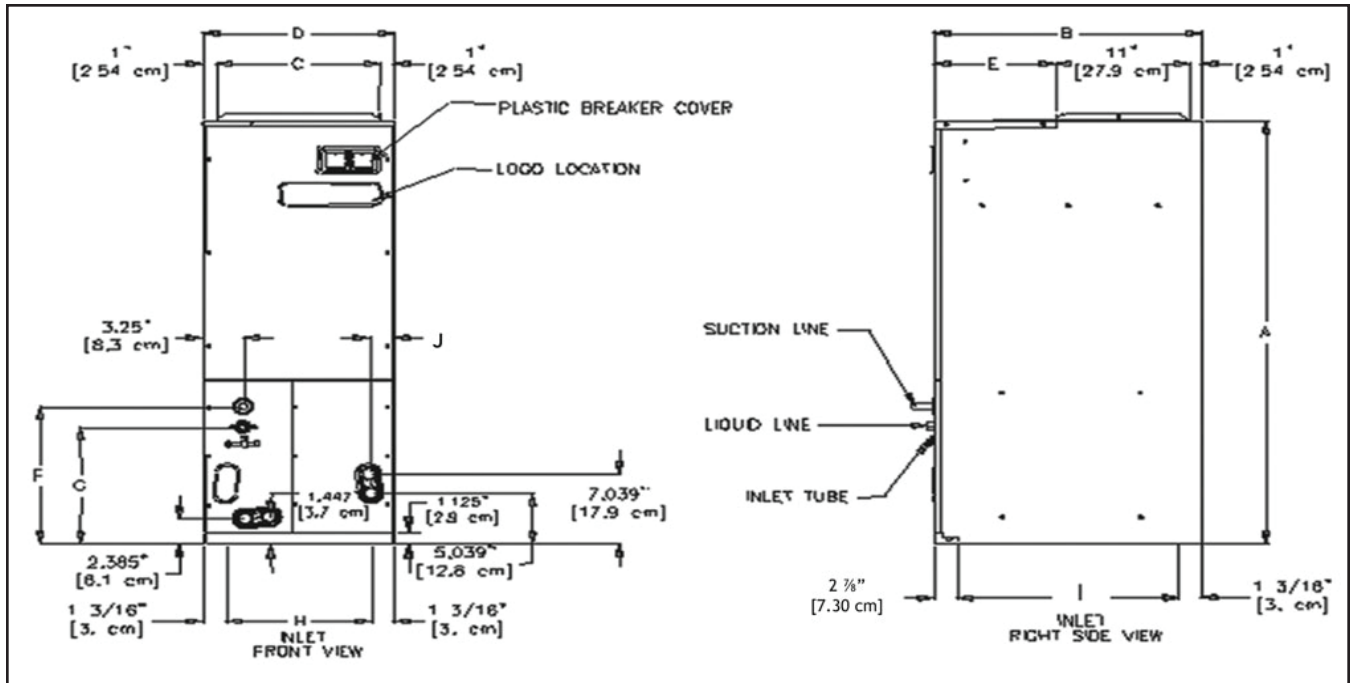

MODEL	A	B	C	D	E	F	G	H	I	J
ASPF183016*	46 3/4"	22"	17 1/2"	19 1/2"	10"	14 1/2"	11 15/16"	17 1/8"	17 15/16"	2"
ASPF303616*	53 3/4"	24"	20"	22"	12"	19 5/8"	11 15/16"	19 5/8"	19 15/16"	1 13/16"
ASPF313716*	53 3/4"	24"	20"	22"	12"	19 5/8"	11 15/16"	19 5/8"	19 15/16"	1 13/16"
ASPF426016*	53 3/4"	24"	20"	22"	12"	19 5/8"	11 15/16"	19 5/8"	19 15/16"	1 13/16"

## AIRFLOW DATA

MODEL	MOTOR SPEED TAP	CFM DELIVERED AGAINST EXTERNAL STATIC PRESSURE				
		0.1"	0.2"	0.3"	0.4"	0.5"
ASPF183016*	Low (T1)	700	670	650	595	510
	Med-Low (T2)	820	785	765	745	705
	Medium (T3)	920	900	850	840	815
	Med-High (T4)	1,075	1,055	1,015	975	960
	High (T5)	1,130	1,115	1,085	1,040	1,000
ASPF303616*	Low (T1)	1,060	865	600	515	420
	Med-Low (T2)	1,105	910	795	745	690
	Medium (T3)	1,165	1,070	1,020	960	915
	Med-High (T4)	1,285	1,240	1,195	1,140	1,100
	High (T5)	1,435	1,395	1,350	1,315	1,265
ASPF313716*	Low (T1)	1,060	865	600	515	420
	Med-Low (T2)	1,105	910	795	745	690
	Medium (T3)	1,165	1,070	1,020	960	915
	Med-High (T4)	1,285	1,240	1,195	1,140	1,100
	High (T5)	1,435	1,395	1,350	1,315	1,265
ASPF426016*	Low (T1)	1,445	1,275	1,175	940	855
	Med-Low (T2)	1,545	1,405	1,325	1,260	1,145
	Medium (T3)	1,660	1,610	1,555	1,490	1,415
	Med-High (T4)	1,905	1,870	1,810	1,750	1,695
	High (T5)	2,115	2,070	2,000	1,965	1,915

**NOTES:**

- Assumes dry coil with filter in place; SCFM correction for wet coil = 4%
- All ASPF models are shipped from the factory with the speed tap set on T4.

# ASPF\*\*\*B\*/D\* WIRING DIAGRAM

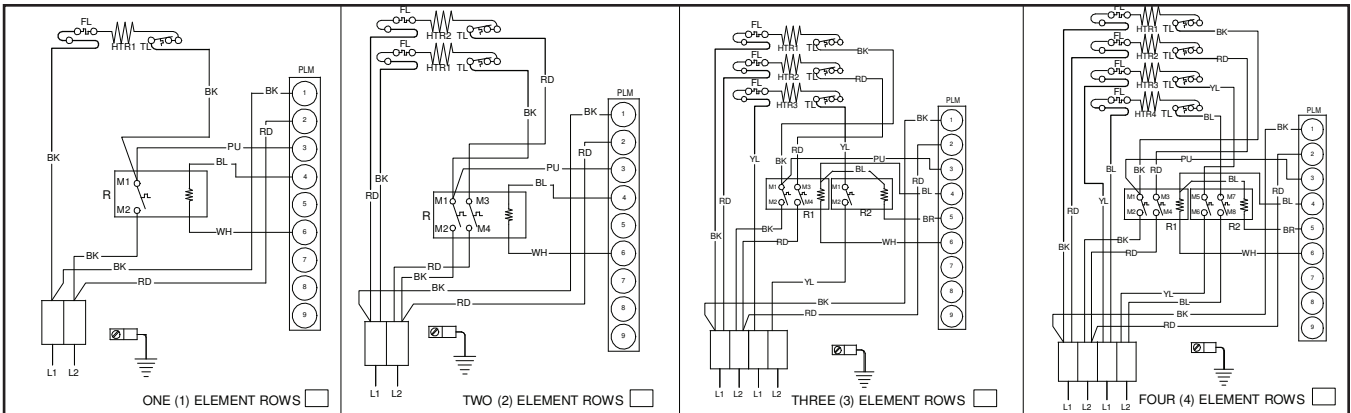

NOTE: WHEN INSTALLING HEATER KIT, ENSURE SPEED TAP DOES NOT EXCEED MINIMUM BLOWER SPEED (MBS) SPECIFIED FOR THE AIRHANDLER/HEATER KIT COMBINATION ON THIS UNIT'S S&R PLATE. AFTER INSTALLING OPTIONAL HEAT KIT, MARK AN "X" IN THE  PROVIDED ABOVE. MARK ACCORDING TO NUMBER OF HEATER ELEMENT ROWS INSTALLED. NO MARK INDICATES NO HEAT KIT INSTALLED.

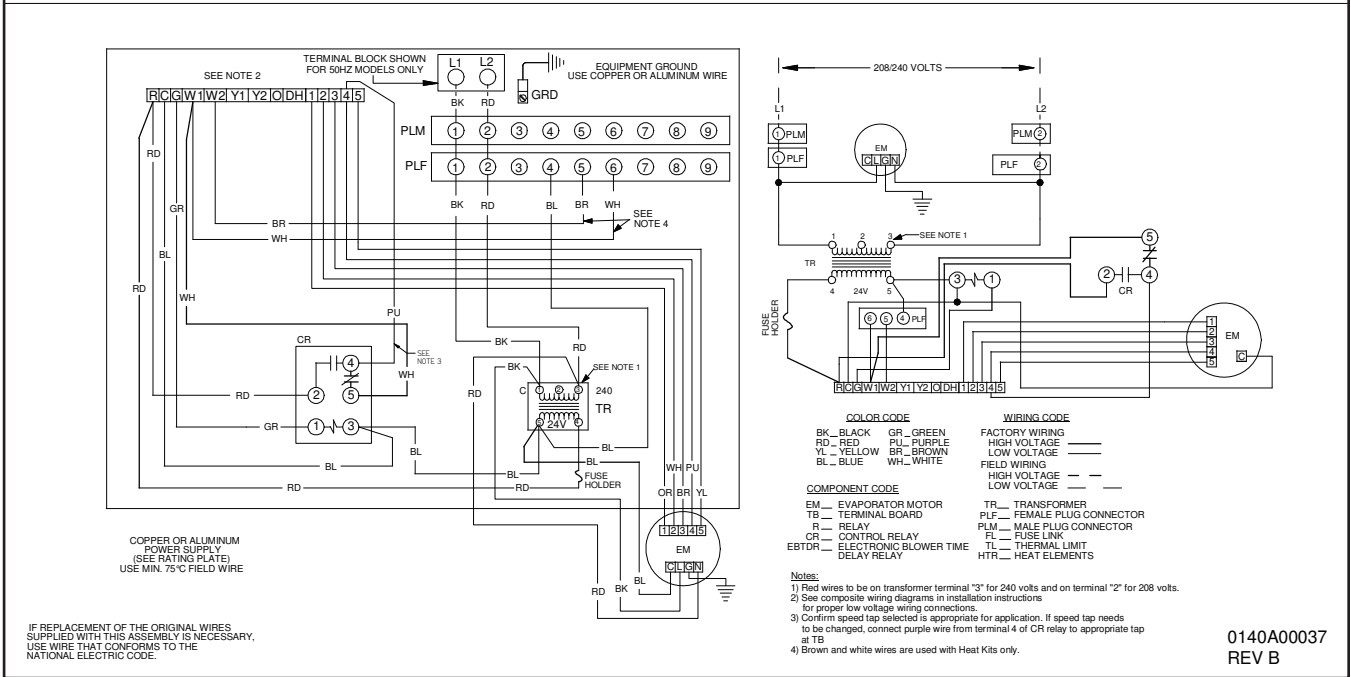

Wiring is subject to change. Always refer to the wiring diagram or the unit for the most up-to-date wiring.



**WARNING**

**High Voltage:** Disconnect all power before servicing or installing this unit. Multiple power sources may be present. Failure to do so may cause property damage, personal injury, or death.



# ASPF\*\*\*C\*/E\* WIRING DIAGRAM

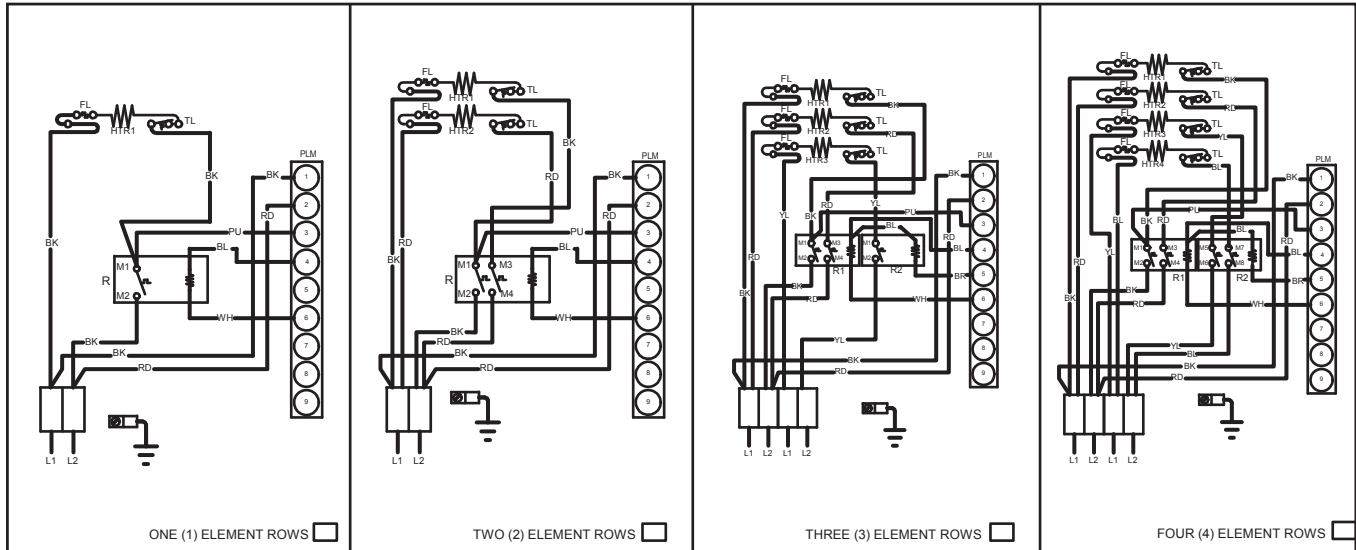

NOTE: WHEN INSTALLING HEATER KIT, ENSURE SPEED TAP DOES NOT EXCEED MINIMUM BLOWER SPEED (MBS) SPECIFIED FOR THE AIRHANDLER/HEATER KIT COMBINATION ON THIS UNIT'S S&R PLATE. AFTER INSTALLING OPTIONAL HEAT KIT, MARK A "X" IN THE  PROVIDED ABOVE. MARK ACCORDING TO NUMBER OF HEATER ELEMENT ROWS INSTALLED. NO MARK INDICATES NO HEAT KIT INSTALLED.

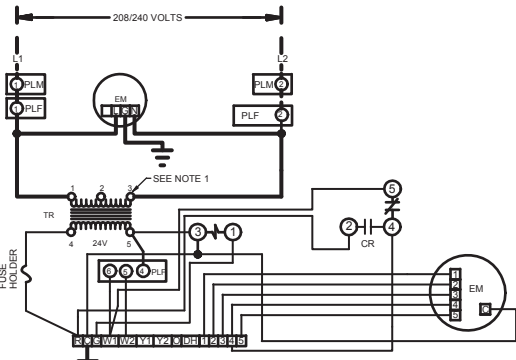
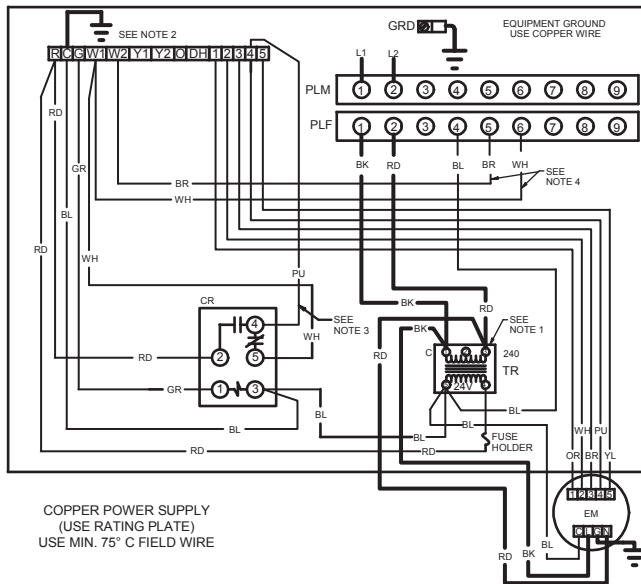

COLOR CODE		WIRING CODE	
BK	BLACK	GR	GREEN
RD	RED	PL	PURPLE
YL	YELLOW	BR	BROWN
BL	BLUE	WH	WHITE
EM	EVAPORATOR MOTOR	TR	TRANSFORMER
TB	TERMINAL BOARD	PLF	FEMALE PLUG CONNECTOR
R	RELAY	PLM	MALE PLUG CONNECTOR
CR	CONTROL RELAY	FL	FUSE LINK
EBTDR	ELECTRONIC BLOWER TIME DELAY RELAY	TL	THERMAL LIMIT
		HTR	HEAT ELEMENTS

- NOTES:
- 1) RED WIRES TO BE ON TRANSFORMER TERMINAL "3" FOR 240 VOLTS AND ON TERMINAL "2" FOR 280 VOLTS
  - 2) SEE COMPLETE WIRING DIAGRAMS IN INSTALLATION INSTRUCTIONS FOR PROPER LOW VOLTAGE WIRING CONNECTIONS.
  - 3) CONFIRM SPEED TAP SELECTION IS APPROPRIATE FOR APPLICATION. IF SPEED TAP NEEDS TO BE CHANGED, CONNECT PURPLE WIRE FROM TERMINAL 4 OF CR RELAY TO APPROPRIATE TAP AT TB
  - 4) BROWN AND WHITE WIRES ARE USED FOR HEAT KITS ONLY.

0140A00040-D

Wiring is subject to change. Always refer to the wiring diagram or the unit for the most up-to-date wiring.

**WARNING**

**High Voltage:** Disconnect all power before servicing or installing this unit. Multiple power sources may be present. Failure to do so may cause property damage, personal injury, or death.

ACCESSORIES

HEAT KIT SELECTION

	ASPF 183016*	ASPF 303616*	ASPF 313716*	ASPF 426016*
HKR-03*	X	X	X	X
HKR-05*, HKR-05C*	X	X	X	X
HKR-06*	X	X	X	X
HKR-08*, HKR-08C*	X <sup>1</sup>	X <sup>1</sup>	X <sup>1</sup>	X
HKR-10*, HKR-10C*	X <sup>1</sup>	X <sup>1</sup>	X <sup>1</sup>	X
HKR-15C*	X <sup>2</sup>	X <sup>2</sup>	X <sup>2</sup>	X <sup>1</sup>
HKR-20C*		X <sup>2</sup>	X <sup>2</sup>	X <sup>1</sup>
HKR-21C*		X <sup>2</sup>	X <sup>2</sup>	
^ HKR3-15*	X <sup>2</sup>	X <sup>2</sup>	X <sup>2</sup>	X <sup>1</sup>
^ HKR3-20*		X <sup>2</sup>	X <sup>2</sup>	X <sup>1</sup>

\* Revision level that may or may not be designated  
 C Circuit breaker option ^ Heat kit requires three-phase power supply  
<sup>1</sup> Air handler must be on speed tap 2, 3, 4, or 5  
<sup>2</sup> Air handler must be on speed tap 4 or 5.

SINGLE POINT KIT \*\*

MODEL	HKR-15C	HKR-20C	HKR-21C
SPW-01	X	X	X

\*\* Must be installed along with any of the above compatible heat kits. This kit will fit any ASPF air handler as long as a compatible heat kit is installed in the unit.

FILTERS

ASPF	FILTER #	QTY REQUIRED
1830	FIL-36-42	1
3036	FIL 48-61	1
4260	FIL 48-61	1

EXPANSION VALVE KITS FOR AIR CONDITIONING  
AND HEAT PUMP APPLICATIONS

KIT NUMBER	DESCRIPTION	APPLICATION	REFRIGERANT	TONNAGE: OUTDOOR UNIT
XVB18-36C	20% Bleed Valve	AC Only	R-22	1½ - 3 Ton
XVB42-60C	20% Bleed Valve	AC Only	R-22	3½ - 5 Ton
XV18-36C	Non-bleed Valve	AC Only	R-22	1½ - 3 Ton
XV42-60C	Non-bleed Valve	AC Only	R-22	3½ - 5 Ton
TX2N2	Non-bleed Valve	AC or HP	R-22	1½ - 2 Ton
TX3N2	Non-bleed Valve	AC or HP	R-22	2½ - 3 Ton
TX5N2	Non-bleed Valve	AC or HP	R-22	3½ - 5 Ton
TX2N4	Non-bleed Valve	AC or HP	R-410A	1½ - 2 Ton
TX3N4	Non-bleed Valve	AC or HP	R-410A	2½ - 3 Ton
TX5N4	Non-bleed Valve	AC or HP	R-410A	3½ - 5 Ton

DRAIN PAN INSULATION KITS  
DOWNFLOW APPLICATIONS

CHASSIS SIZE	INSULATION KIT
Small (15½")	DPI18-30/20
Medium (19½")	DPI36-42/20
Large (22")	DPI48-60/20

Note: Each kit contains enough material to modify 20 coils

HORIZONTAL APPLICATIONS

CHASSIS SIZE	INSULATION KIT
Small (15½")	DPIH18-32
Medium (19½")	DPIH36-42
Large (22")	DPIH48-61

Note: Each kit contains enough material to modify 20 coils

